

Singlsyn[®]

(Superior Flat Absolute Angle Sensor)

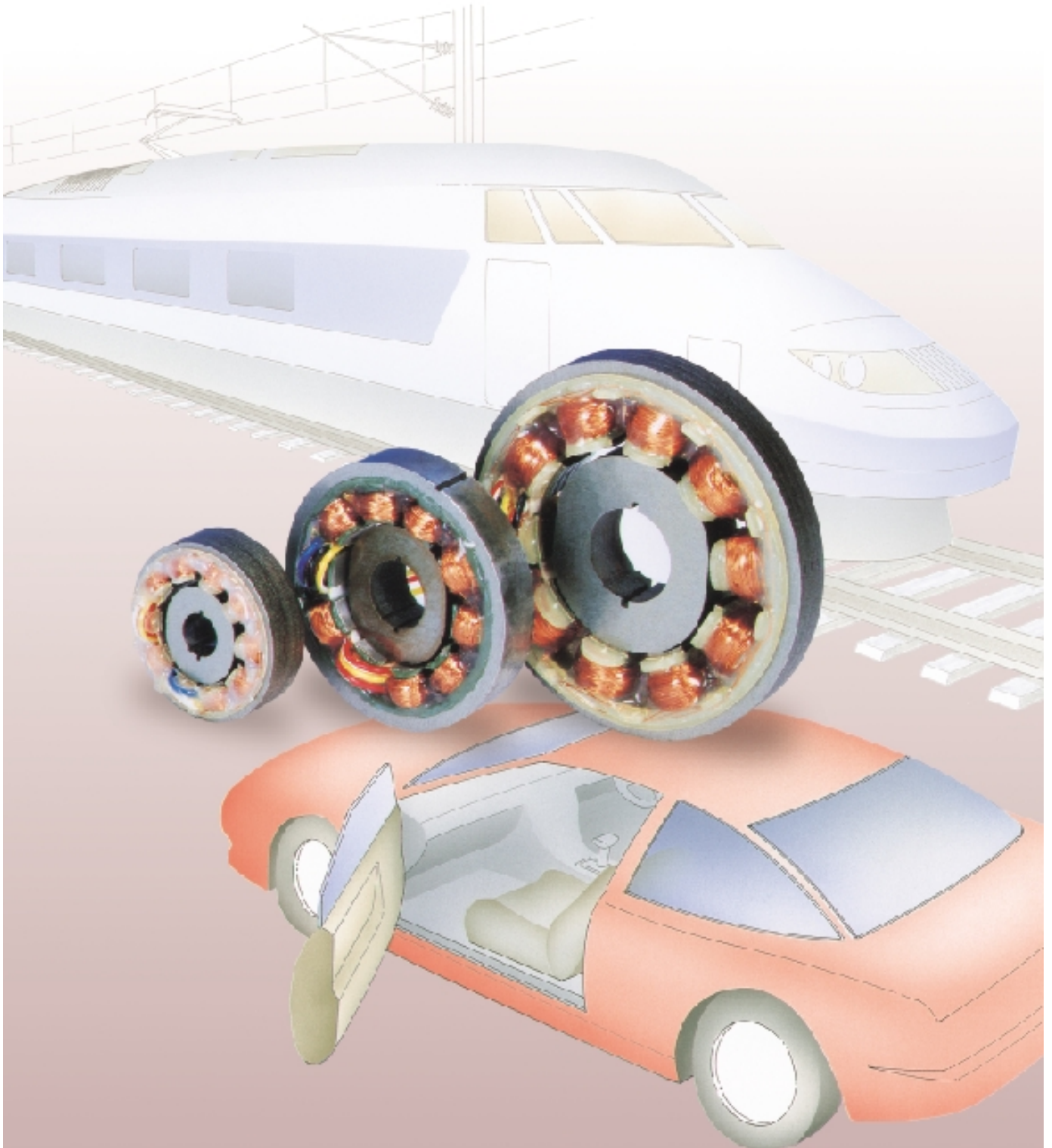

(Superior Flat Absolute Angle Sensor)

SCOPE

Singlsyn is the latest art of Absolute Angle Sensor which is developed by Tamagawa. This is a superior sensor which realizes extremely thin structure, usable wide temperature and humidity range and other hard environmental conditions, and high reliability. (Singlsyn is our trade mark for VR type Resolver.)

SPECIAL FEATURES

■Extremely Thin Dimension

Singlsyn realizes smallest mounting space because of its extremely thin thickness as a built-in structure.

■Wide Temperature Range

-5-5°C ~ +155°C

■Robust for Hard Environments

- Vibration : 20 gs
- Shock : 100 gs
- Humidity : Up to 90% RH

■High Rotational Speed

Up to 30,000 min⁻¹ (rpm)

■High Reliability

Singlsyn has the similar structure with electric motor but has high reliability because of no winding coil on the rotor.

■Sensing Absolute Position and Velocity

According to connect to R/D converter or **Smartcoder**, it is capable to convert the analog output signal of Synglsyn to digital position (angle). The position signal is transmitted as the absolute position within the range of electrical one cycle.

■Low Cost

Especially low cost is realized by reducing the number of parts to 1/10 compared with the conventional resolver.



APPLICATIONS

- Detection for Rotational Position of Motor and Generator on Hybrid Vehicle
- Detection for Rotational Position of Motor on Electric Vehicle

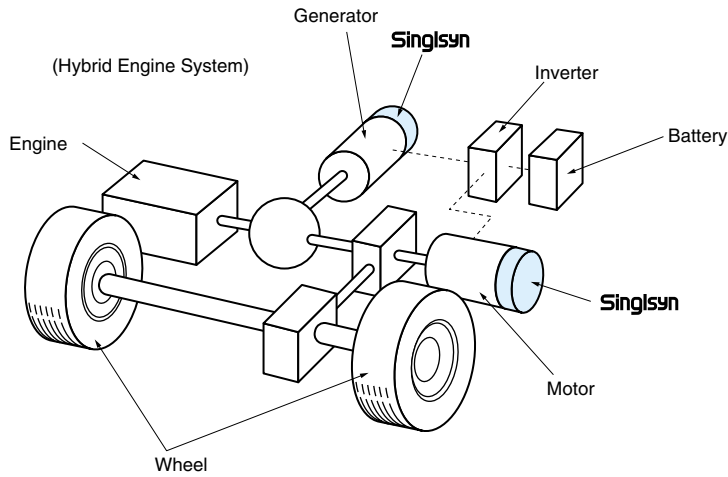

- Angle Detection for Magnetic Pole of Motor in Electrical Power Steering

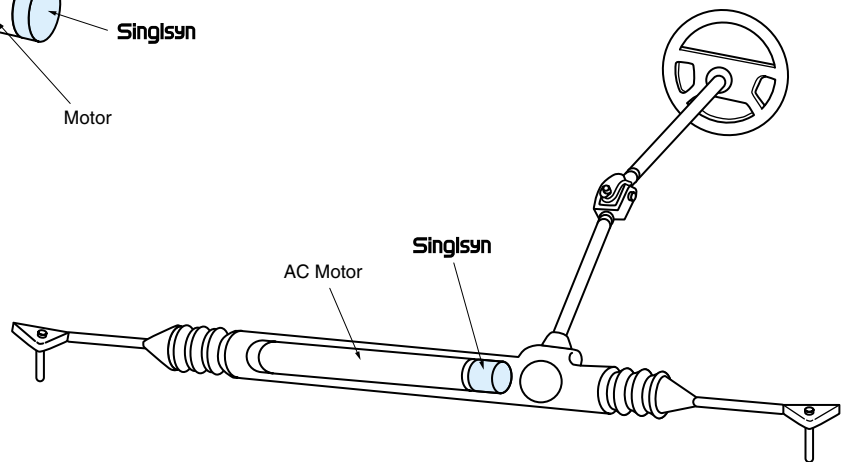

- Angle Detection for Controlling Fuel Valve (Air Valve)

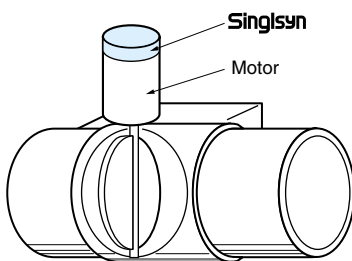

- Angle Detection for conveyer in Vacuum

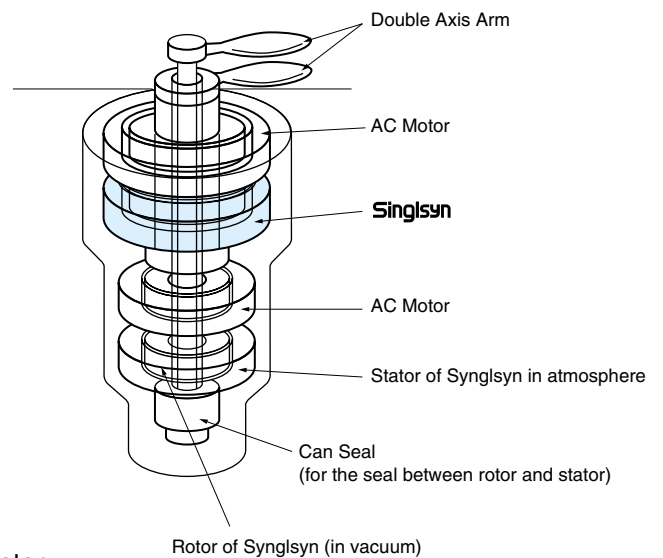

- Angle Detection for Control of Switched Reluctance Motor
- Angle Detection for Vector Control of High Efficient Induction Motor
- Angle Detection for Rotational Control of AC Motor (PM Motor)

PRINCIPLE OF OPERATION

The contour of rotor for **Synglsyn** forms specially curved air gap between its stator and rotor which its permeance is changed as a sinusoidal wave corresponding to the angle of the rotor shaft. One excitation winding and two output windings are placed in the stator. The two output windings detect the change of air gap between the rotor and stator and produce its output voltage with 2-phases proportional to sine and cosine of the angle of rotor. (Refer Fig. 1 and Fig. 2)

Because the output signals of **Synglsyn** are the same as that of conventional resolvers and Smartsyns as shown in equation (2) and (3), they can be converted to digital angle data by using conventional resolver to digital (R/D) convertors.

The **Synglsyn** which produces twice angle output signal (2X type) has an elliptical shape of rotor as shown in Fig. 3 (a). The rotor for 3X type is triangular and cross shaped for 4X type as shown in Fig. 3 (b) and 3 (c).

<Excitation Voltage>

$$E_{R1-R2} = E \sin \omega t \quad (1)$$

<Output Voltage>

$$E_{S1-S3} = K = E \sin \omega t \cdot \cos (X \cdot \theta) \quad (2)$$

$$E_{S2-S4} = KE \sin \omega t \cdot \sin (X \cdot \theta) \quad (3)$$

where

- K : Transformation Ratio
- t : Time (s)
- θ : Shaft Angle (deg)
- f : Excitation Frequency (Hz)
- ω : $2 \pi f$
- E : Excitation Voltage (V)
- X : Multiplication Factor of Angle (X = 2, 3 or 4)

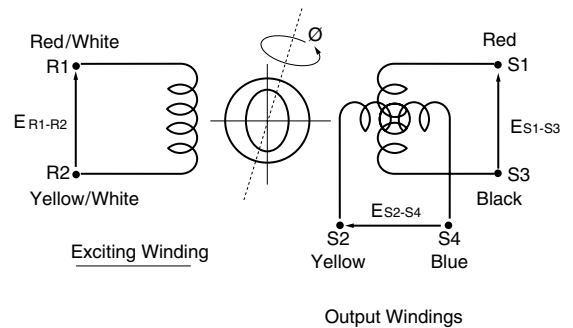

Fig. 1 Wiring Diagram

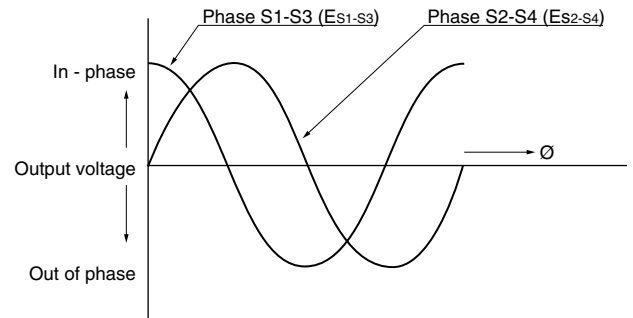

Fig. 2 Output Voltage Characteristics

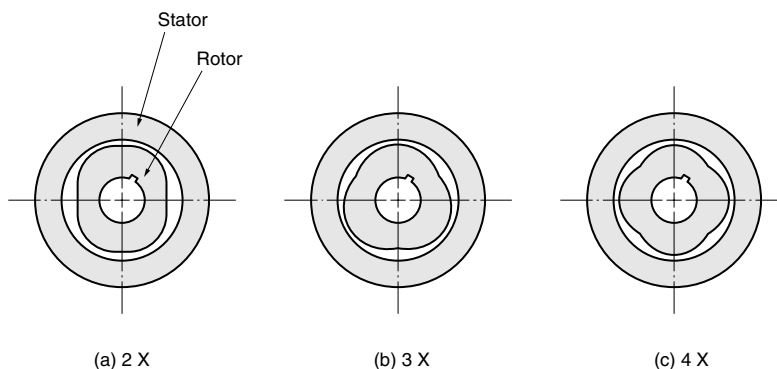

Fig. 3 Shape of Rotor

HISTORY OF DOWN-SIZING AND LESS-PARTS ON RESOLVER

Tamagawa Seiki Co., Ltd. has been developing and manufacturing more than 40 years. The progress regarding Resolver was a history of reducing its size and cost at same time.

Originally the military specification of resolver with brushes has two windings on both the rotor and the stator. After Resolver comes through the brushless type and built-in type, **Smartsyn** has still needed four windings of rotor, stator and rotary transformer (rotor and stator).

Comparing with these conventional resolvers, the newly developed VR (Variable Reluctance) type resolver needs the winding in stator only. We named this new product **Singlsyn**.

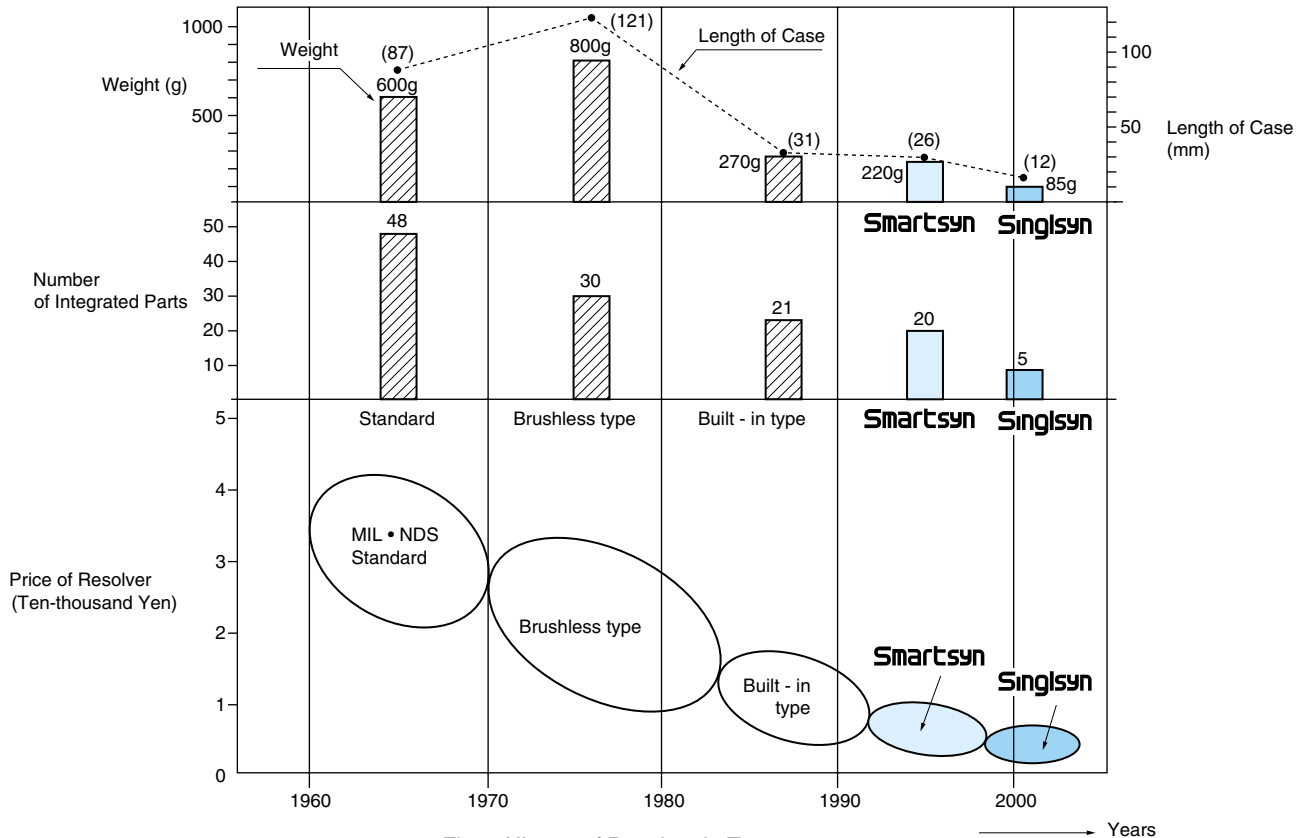

Fig. 4 History of Resolver in Tamagawa

Structural Comparison of Smartsyn and Singlsyn

The structural differences between the conventional winding type brushless resolver (**Smartsyn**) and the new developed **Singlsyn** is shown in Fig. 5.

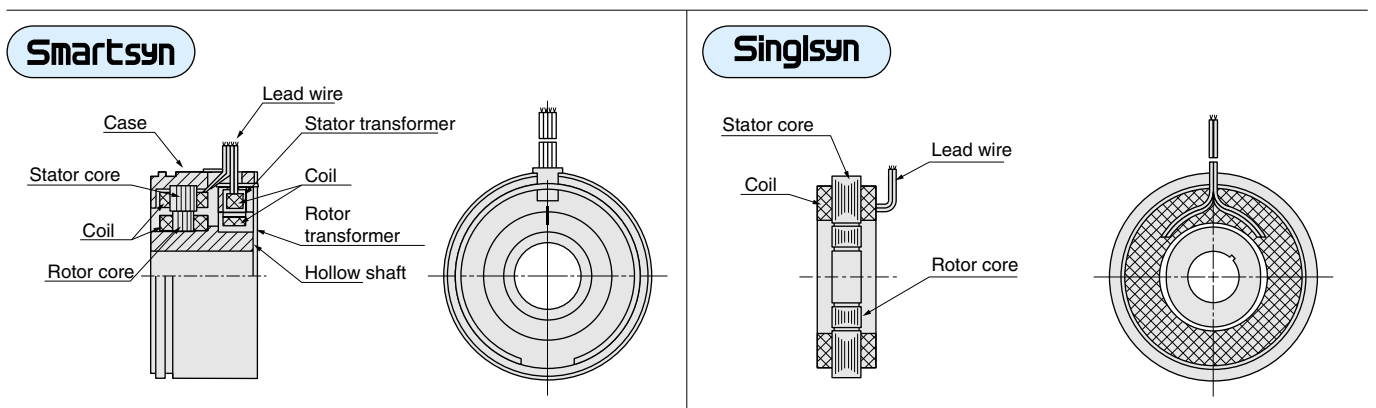

Fig. 5 Structural Comparison of **Smartsyn** and **Singlsyn**

SPECIFICATION

FUNCTION	2X-BRX			3X-BRX			4X-BRX		
	S10	S15	S21	S10	S15	S21	S10	S15	S21
Model Number	TS2223N12E10 2	TS2224N12E10 2	TS2225N12E10 2	TS2223N13E10 2	TS2224N13E10 2	TS2225N13E10 2	TS2223N14E10 2	TS2224N14E10 2	TS2225N14E10 2
Excitation Input	AC7Vrms 10kHz			AC7Vrms 10kHz			AC7Vrms 10kHz		
Primary Side	R1 - R2			R1 - R2			R1 - R2		
Transformation Ratio	0.286 ± 10%			0.286 ± 10%			0.286 ± 10%		
Electrical Error	±60°MAX			±45°MAX			±30°MAX		
Input Impedance: Zro	120 Ω ± 20%			120 Ω ± 20%			120 Ω ± 20%		
Output Impedance: Zss	350 Ω NOM	250 Ω NOM	270 Ω NOM	330 Ω NOM	260 Ω NOM	290 Ω NOM	430 Ω NOM	340 Ω NOM	335 Ω NOM
Phase Shift	+ 15° TYP	+ 10° TYP	0° TYP	+ 25° TYP	+ 5° TYP	0° TYP	+10° TYP	0° TYP	-10° TYP
Weight	0.023kg	0.050kg	0.090kg	0.023kg	0.050kg	0.090kg	0.023kg	0.050kg	0.090kg

OUTLINE DIMENSIONS

S10// TS2223N10 Series

2X : TS2223N12E102
3X : TS2223N13E102
4X : TS2223N14E102

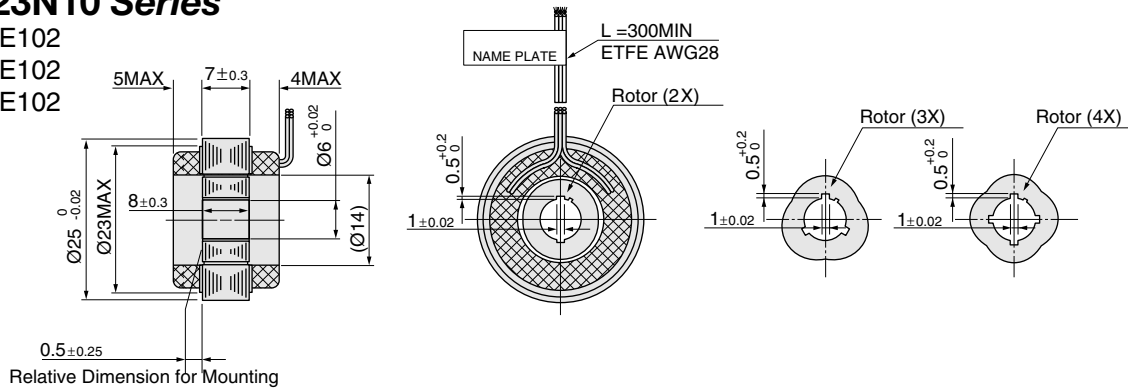

S15// TS2224N10 Series

2X : TS2224N12E102
3X : TS2224N13E102
4X : TS2224N14E102

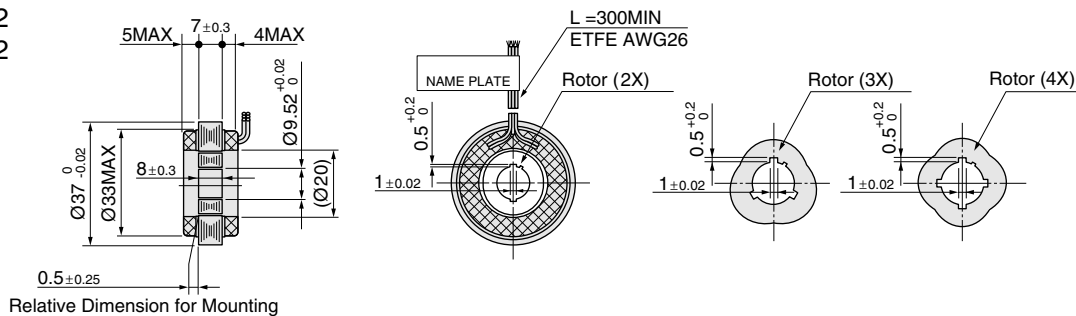

S21// TS2225N10 Series

2X : TS2225N12E102
3X : TS2225N13E102
4X : TS2225N14E102

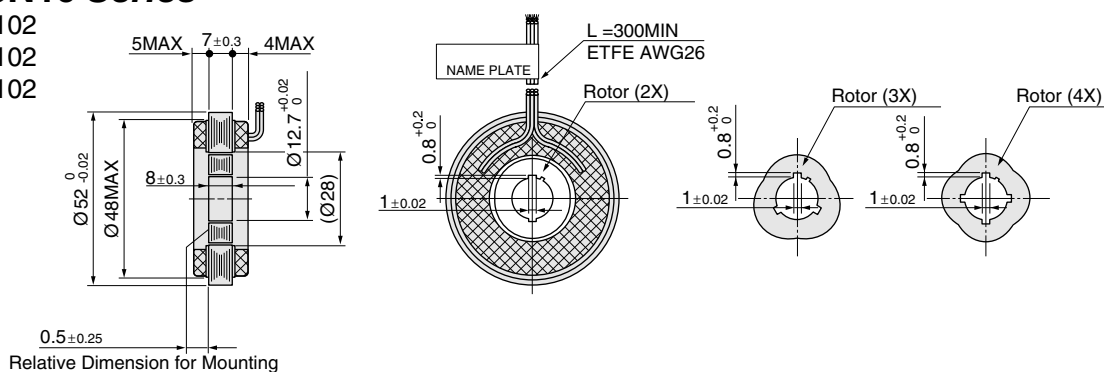

All dimensions are described in milli-meter.

MOUNTING METHOD AND ACCURACY

●Mounting Method (Built-in type)

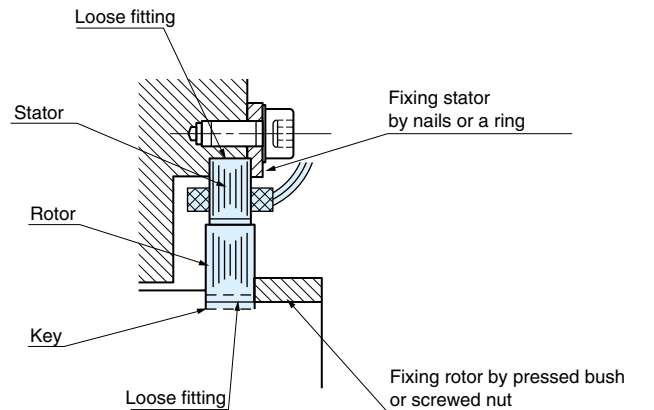
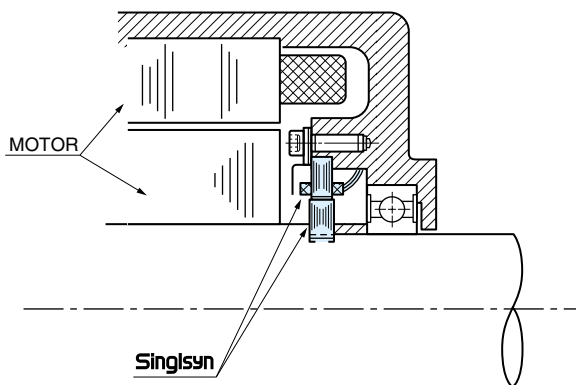
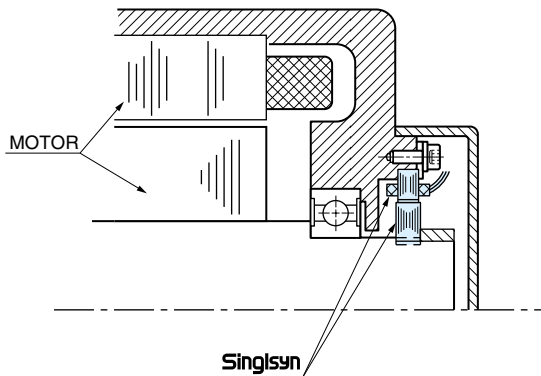

Detail Drawing for mounting **Singlsyn**

●Electrical error caused by the Stator Eccentricity error of 0.05 mm

Function		2X-BRX	3X-BRX	4X-BRX
Size	S10	45'	10'	5'
	S15	35'	3'	2'
	S21	10'	2'	1'

●Electrical error caused by the Rotor Eccentricity error of 0.05 mm

Function		2X-BRX	3X-BRX	4X-BRX
Size	S10	30'	3'	3'
	S15	10'	2'	1'
	S21	3'	1'	1'

●Mounting Accuracy

In case **Singlsyn** is mounted in rough accuracy, the performance of **Singlsyn** may not be fully performed.

The eccentricity between the rotor and stator affects to its electrical accuracy as shown in the right table.

●Allowable Axial Deflection

The deflection in the axial direction between the stator and rotor should be within ± 0.25 mm.

Caution for Use

- The excitation input voltage in the specification sheet is described as the rated value. It is no problem for use in the range from 3 V to 1.2 times of the rated voltage, but the frequency should be $\pm 5\%$ of the rated value. Or else it may cause to degrade its accuracy.
- In case of presence of large noise source near or use of long transmission line, basically twisted pair lines with shield in each pair should be used. Additionally the difference amplifier should be used as receiver if any noise is induced in output signal.
- If **Singlsyn** is mounted with out of eccentricity, tilt or run-out for the shaft of measuring object, some significant electrical error may occur in output signal of **Singlsyn**. Therefore the users should be care of mounting **Singlsyn** mechanically as described in above Mounting Method.
- If **Singlsyn** is connected to unbalanced load for each output of 2-phases, two output voltages become unbalance and may result to produce some electric error. Therefore the load of 2-phases should be the same condition.
- In case of the presence of strong external magnetic field around **Singlsyn**, it affects the magnetic flux in **Singlsyn** and may result to produce some electrical error. Therefore please consider to set some shielding for **Singlsyn** in this case.
- Being **Singlsyn** used in the condition of relative humidity of near 100% for long time, the electrical insulation of **Singlsyn** may be worse gradually. Therefore using of some protected cover for **Singlsyn** is recommended.



TAMAGAWA TRADING CO.,LTD.

A COMPANY OF TAMAGAWA SEIKI CO.,LTD.

HEAD OFFICE:

1879 OHYASUMI, IIDA, NAGANO PREF, 395-8515, JAPAN

PHONE : 0265-21-1840

FAX : 0265-21-1864

WARRANTY

Tamagawa Seiki warrants that this product is free from defects in material or workmanship under normal use and service for a period of one year from the date of shipment from its factory. This warranty, however, excludes incidental and consequential damages caused by careless use of the product by the user. Even after the warranty period, Tamagawa Seiki offers repair service, with charge, in order to maintain the quality of the product. The MTBF (mean time between failures) of our product is quite long; yet, the predictable failure rate is not zero. The user is advised, therefore, that multiple safety means be incorporated in your system or product so as to prevent any consequential troubles resulting from the failure of our product.



EMS Accreditation
RE012

ISO 14001



OS Accreditation
R014



ISO 9001



All specifications are subject to change without notice.

URL <http://www.tamagawa-seiki.co.jp>

'99.4

T12-1579 . 2,000 . 1999 . 4